

Principle 6: Grow Innovative Business and Employment Opportunities

Grow innovative business opportunities that support the knowledge-based innovation sector, green jobs and knowledge-based industries, within a compact, mixed use community



Objectives

- a) Accommodate a significant share of Guelph's employment growth to 2031.
- b) Establish the role of the GID as a key area supporting the growth of a knowledge-based innovation cluster, which may include the agriculture, environment, information technology, advanced manufacturing, health and related science sectors, making connections to the Downtown and the University.
- c) Nurture and capitalize on the GID as a recreational and tourist destination.
- d) Create a setting that reinforces the GID as a high density employment area that attracts provincially, nationally and/or internationally significant employment uses.
- e) Encourage employment uses within the historic Reformatory Complex that can showcase the site's built heritage resources and cultural heritage landscape.
- f) Target the GID as a key location for knowledge-based innovation sector businesses, green jobs and knowledge-based industries such as the information and communication technology sector and post-secondary institutions.
- g) Support strategic and collaborative economic development partnerships within the GID and surrounding community.
- h) Encourage a supportive business environment by fostering learning and innovation within the GID.
- i) Encourage economic opportunities for the GID that contribute to innovative and sustainable employment uses that are compatible with a mixed use environment, including residential uses.
- j) Protect and support existing industrial uses, recognizing their contribution to the City's overall employment, waste management services, and carbon footprint reduction.

Policy Highlights

- New development to offer opportunities for people to live, work, play and learn
- Support and accommodate emerging innovation businesses and other "green" energy industries to support the emergence of the District as an innovation centre together with the knowledge-based research centre located within the University of Guelph and with the civic hub and cultural centre of Downtown
- Encourage small and medium-scale retail commercial uses
- Contribute to achieving the City-wide Population and Employment and density targets for 2031, the GID is planned to achieve:
 - a) 8,000 – 10,000 jobs
 - b) 3,000 – 5,000 people

Policy Highlights

- Identifies key implementation tools
 - Density bonusing for carbon neutral development
 - Alternative development standards, servicing and stormwater management ...
- Partnerships are key
 - Business Case Assessments
 - District Energy
- Implementation Strategy - carbon neutral development focus
 - Carbon neutrality targets
 - Mechanisms, tools and initiatives that can be utilized to achieve these targets
- Presents four development phases

Phasing Schedule

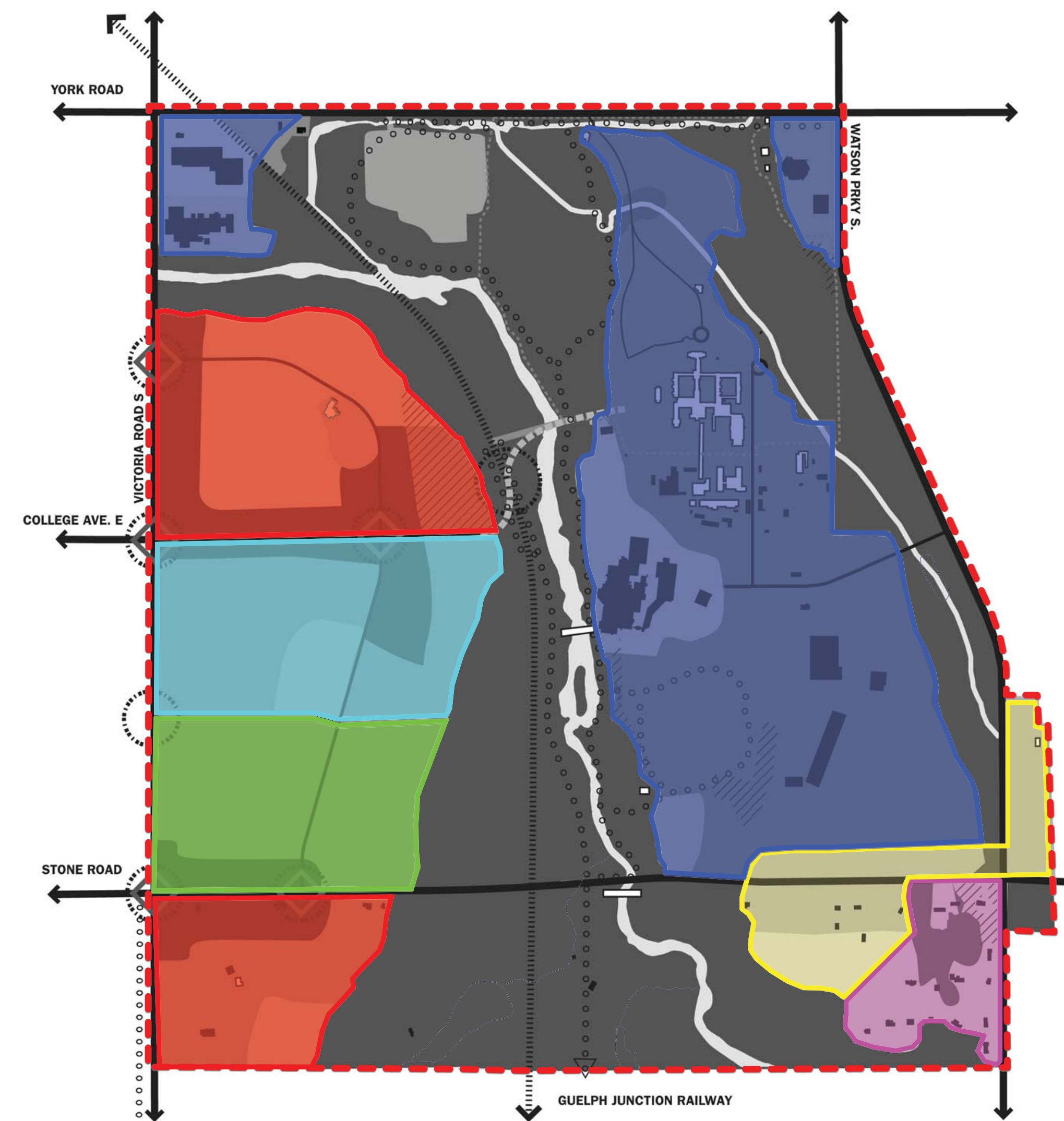

Height Schedule

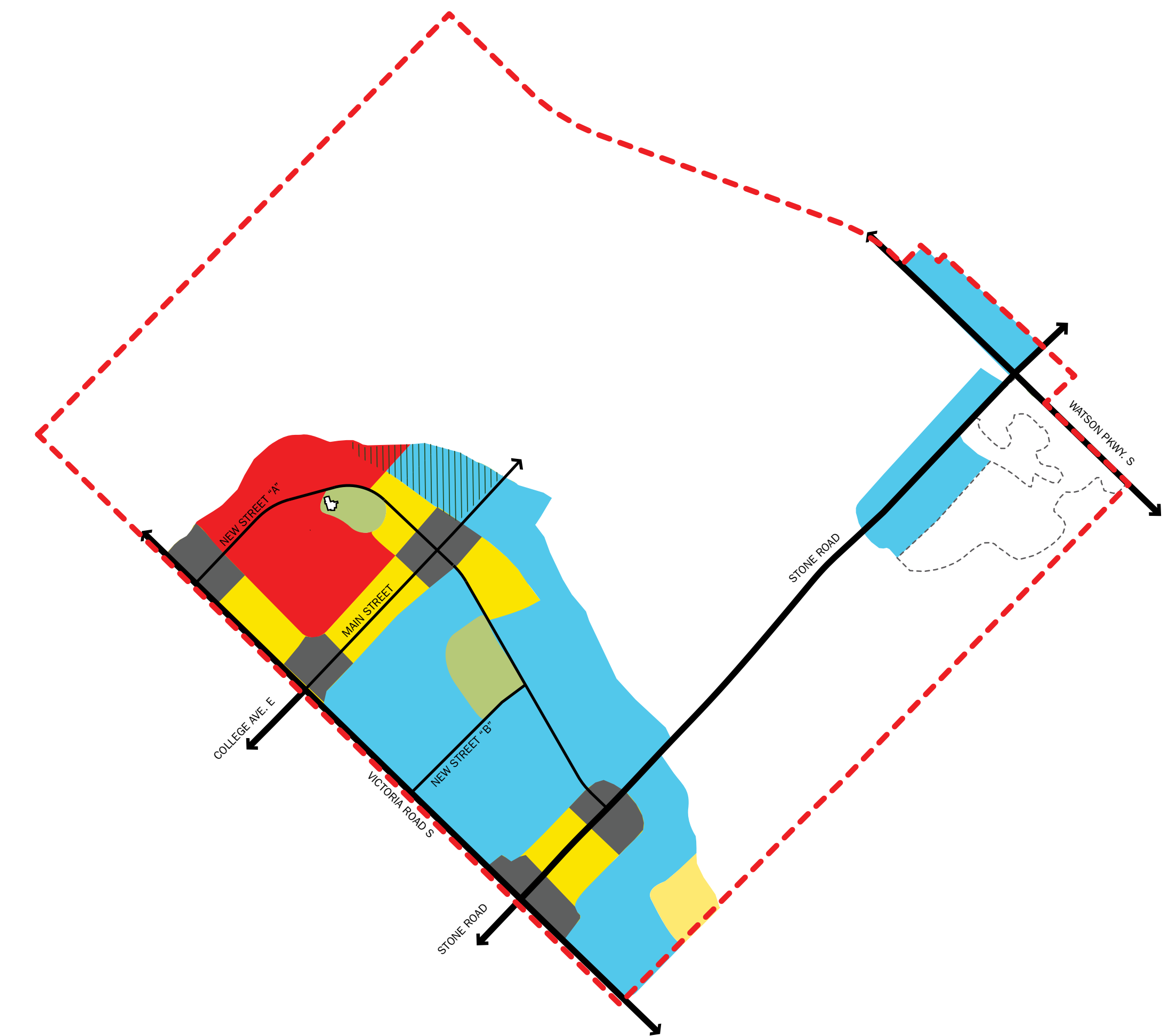

- Phase 1
- Phase 2
- Phase 3
- Phase 4
- Existing Municipally Serviced Area
- Existing Privately Serviced Area

- Open Space and Park
- Existing Natural Area
- Refer to Policy 6.3.34
- 2 min - 5 max Storeys
- 4 min - 6 max Storeys
- 4 min - 8 max Storeys
- 10m min - 6 max Storeys

